

PRESENZA

ITALIA

RAIN SHOWER SYSTEM WITH HANDSHOWER



WM-022655

USER MANUAL

ITM. / ART. 51567

QBA044

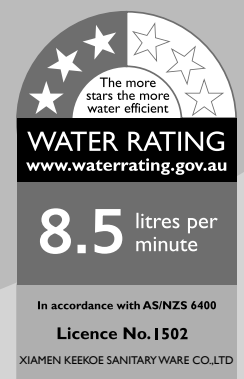

Rev. 20191029

Table of Contents

Safety Information	2	Installation	6
Warranty		Operation	9
One Year Limited Warranty	3	Troubleshooting	9
Warranty Claim Procedure	3	Maintenance	9
Pre-Installation		Service Parts	10
Tools/Materials Required	4		
Package Contents	5		

Safety Information

READ AND SAVE THESE INSTRUCTIONS

1. Inspect this product before proceeding. Unpack the contents of the package and check the components for chips, scratches, cracks, dents or scuff marks. If any damage is noticed, do not install.
2. Use this product only in the manner intended by the manufacturer. If you have any questions, contact the manufacturer.
3. Installation work and plumbing must be done by qualified person(s) in accordance with all applicable codes and standards.
4. Protect the entire surface during installation.



CAUTION: Always wear safety goggles and gloves during installation to prevent personal injury.

BEFORE YOU BEGIN

1. This unit might not be suitable for installation with some fiberglass or acrylic showers.
2. This product will connect to your current shower valve. There is no need to take out your current valve or change it.

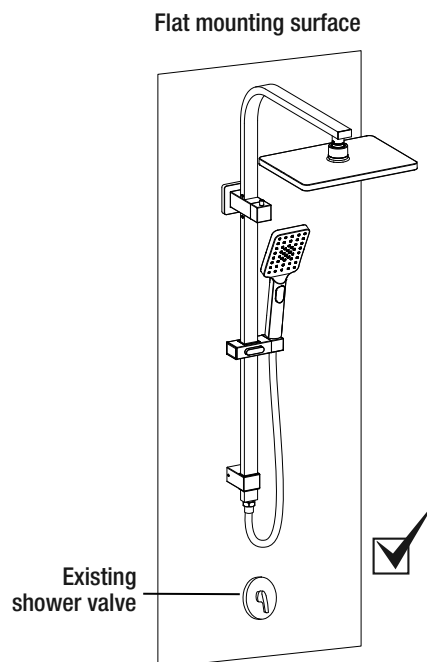

Warranty

ONE YEAR LIMITED WARRANTY

A thorough inspection must be made before installation and any damage must be promptly reported. We will not be liable for failures or damage that could have been discovered or avoided by proper inspection and testing prior to installation.

Conglom Inc. warrants this product to be free from defects in materials or workmanship for one (1) year from the date of purchase. Proof of purchase (original sales receipt) from the original consumer purchaser must be made available to Conglom Inc. for all warranty claims.

This warranty is non-transferable and shall be voided if the unit is removed from its initial installation or if it is not installed following the manufacturer's instructions. It does not apply in the event of product damage due to the use of other than genuine Conglom Inc. replacement parts, (Replacement parts may be obtained by e-mail at cs@conglomkb.com or by calling +61 1800 CONGLOM between 6:30 am - 3:00 pm AEDT) installation error, abuse, misuse or improper care and maintenance (whether performed by a plumber, contractor, service provider or member of the purchaser's household). The warranty excludes damage due to aggressive air or water conditions, harsh or abrasive cleaners and/or materials.

Under no circumstance shall we be held liable for personal injury or property damage resulting from improper installation or use of this product. We will not be held liable for inconvenience caused by loss of use of this product, costs incurred for labour or materials, removal and installation of replacement units, or any other incidental or consequential damages. Costs relating to obtaining access for repair or replacement are the responsibility of the user.

Our obligation shall be limited to the repair or replacement of a unit (at our discretion) that may prove, by our sole examination, to be defective under normal use and service during the warranty period.

Any failure of this product that is not traceable to a defect in material or workmanship is not covered by this warranty. These non-warrantable items include, but are not limited to:

- Improper installation not in accordance with manufacturer's instructions.
- Dents and/or scratches incurred during shipping, handling, or installation.
- Change in colour or finish due to chemical usage.
- Damage caused by failure to follow care and cleaning guidelines, including damage caused by the use of abrasive cleaners.
- Alterations made to the unit by the purchaser or installer.
- Damage caused by accidental impact, fire, flood, freezing, and normal wear.
- Bends and warping caused by forced connections, over-tightened fittings, and inadequate support during installation.
- Do not allow your acrylic surface to come into contact with products such as acetone (nail polish remover), nail polish, dry cleaning solution, lacquer thinners, gasoline, pine oil, etc.

This warranty does not extend to commercial and institutional installation or use.

WARRANTY CLAIM PROCEDURE

If a claimable defect occurs or replacement parts are needed, please contact our customer service team at cs@conglomkb.com or +61 1800 CONGLOM (Service available Monday - Friday from 6:30 am - 3 pm AEDT).

Before you make your call, please ensure that you have:

- Model number or description.
- Proof of sale.
- Details regarding the defect and/or part number.
- Name(s) and address(es) of the owner and/or installer.

Pre-Installation

TOOLS/MATERIALS REQUIRED (NOT SUPPLIED)

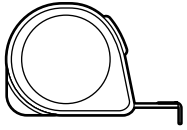

Measuring tape

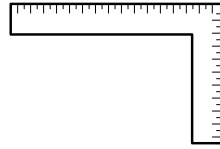

Carpenter's square



Wrenches

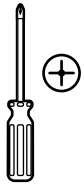

Phillips screwdriver

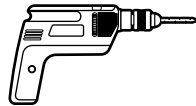

Electric drill with
6 mm drill bit

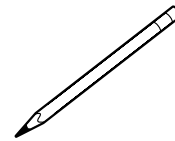

Pencil



Safety gloves



Safety goggles



Level

Pre-Installation (continued)

PACKAGE CONTENTS

Unpack and inspect package contents before proceeding. If you are missing parts or if you require replacement parts, please contact our customer service team at cs@conglomkb.com or +61 1800 CONGLOM (Service available Monday - Friday from 6:30 am - 3 pm AEDT).

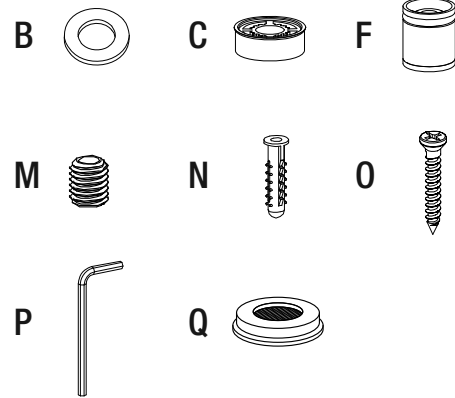
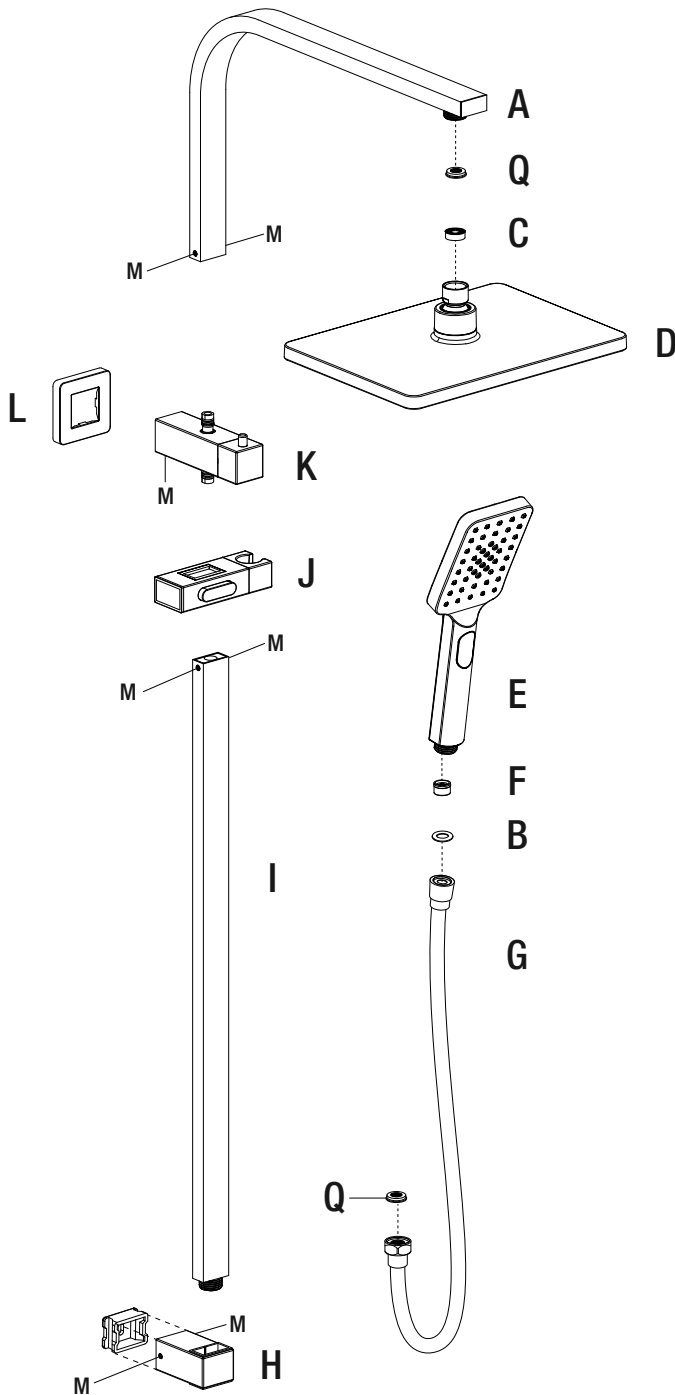

Part	Description	Qty
A	Overhead arm	1
B	Gasket	1
C	Flow controller	1
D	Shower head	1
E	Hand shower	1
F	Flow controller with check valve	1
G	Hose	1
H	Bottom Bracket	1
I	Slider arm	1
J	Hand shower holder	1
K	Diverter	1
L	Flange cover	1
M	Set screws	8
N	Wall anchors	1
O	Screw	1
P	Hex key	1
Q	Strainer gasket	2

NOTE:

Parts shown not to scale.

Pre-installed parts denoted with dashed lines.

Installation

This product is designed to connect to your existing plumbing. Your shower valve, diverter valve or diverter tub spout will be used in its current position and will operate as before, see Fig. 2.

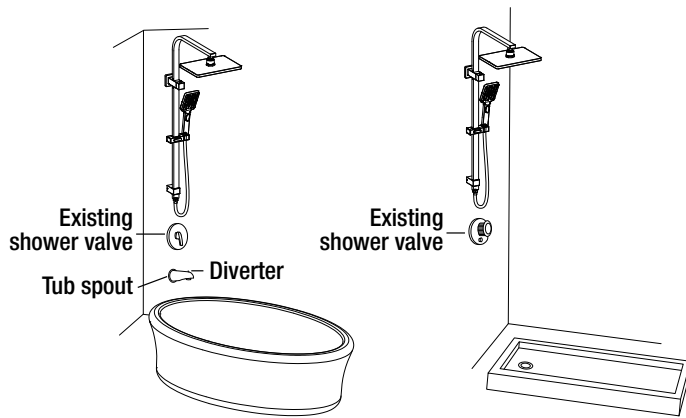

Fig.2

- Install the base of bracket (H) by using the provided wall anchor (N) and screw (O).

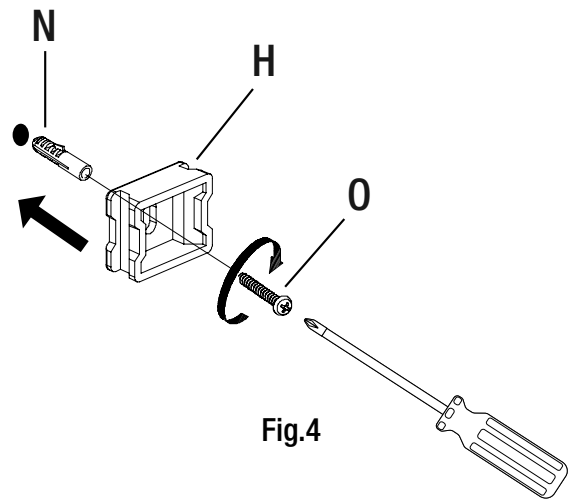

Fig.4

SHOWER HEAD INSTALLATION

- Mark a spot approximately 560 mm from the center of the BSP thread (shower wall outlet) and drill a 6 mm hole for the bottom bracket (H) as shown in Fig. 3 and 4.

NOTE:

The bracket (H) can be secured slightly higher or lower depending on your location.

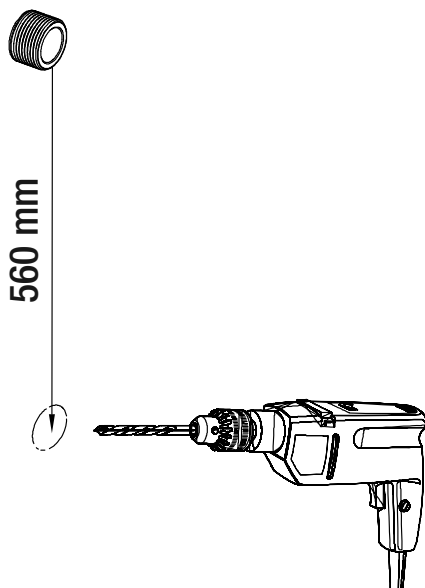

Fig.3

- Apply thread seal tape to threaded shower outlet. Insert diverter (K) through flange cover (L) and fasten them to wall outlet, then fix diverter (K) by using set screw (M), see Fig.5.

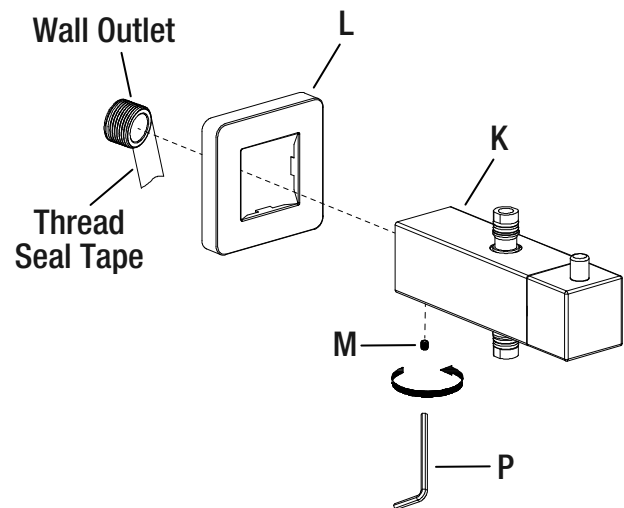

Fig.5

Installation (continued)

- Slide the bottom bracket (H) and the hand shower holder (J) onto the top of the slider arm (I) as shown in figure 6. You may need to adjust the set screws of the slider arm (I) to do so.

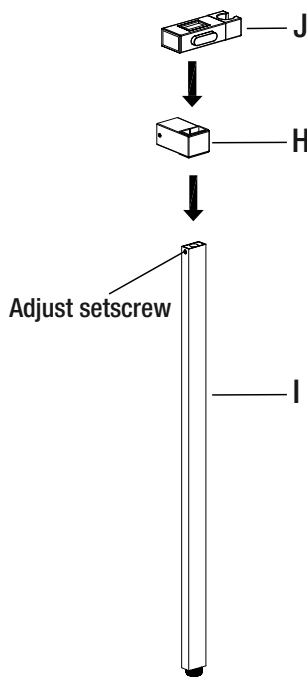

Fig.6

- Carefully connect the top of the slider arm (I) to the diverter (K) and secure it in place with the set screws (M) as shown below.

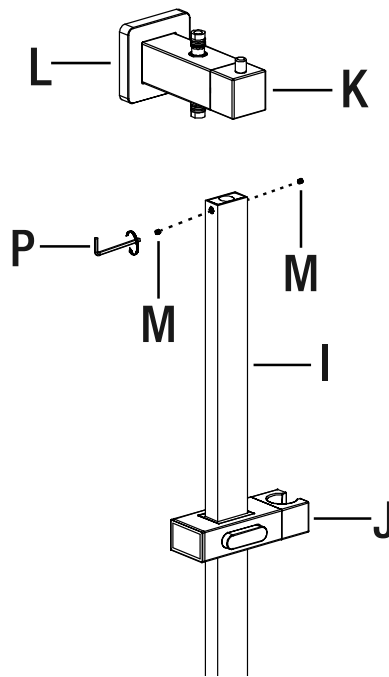

Fig.8

- Affix the bottom bracket (H) to the wall mounted base and tighten the set screws (M) as shown in figure 7.

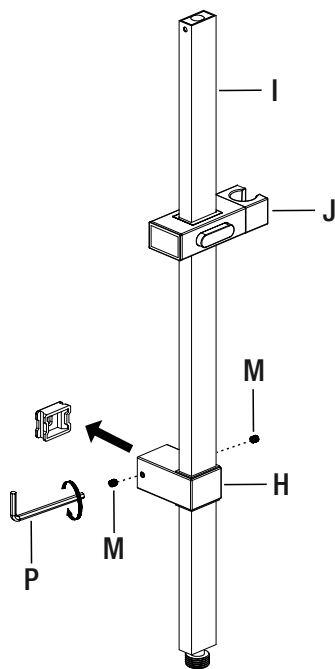

Fig.7

- Carefully connect the overhead arm (A) to the diverter (K) and secure it in place using the set screws (M) as shown below.

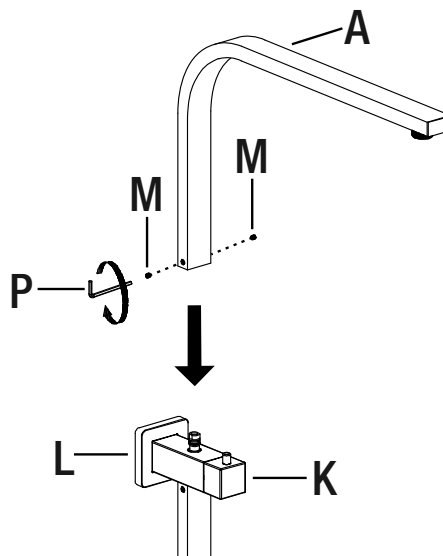

Fig.9

Installation (continued)

- Connect the shower head (D) to the overhead arm (A), making sure the pre-installed gasket (Q) and flow controller (C) are in place.

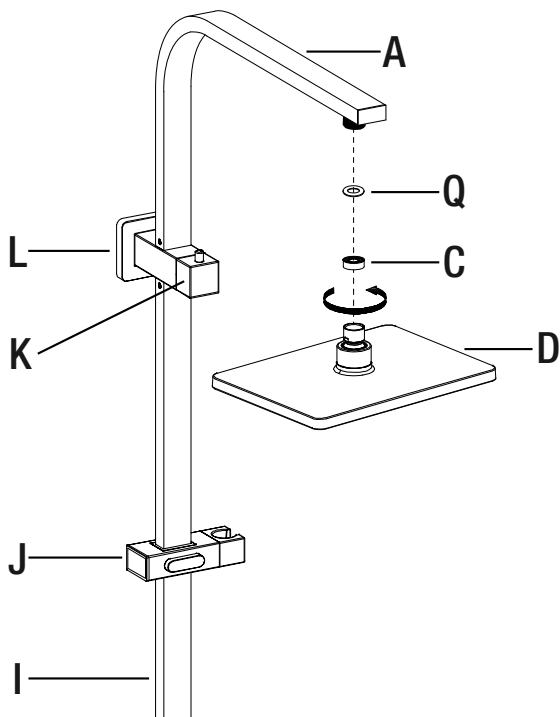

Fig.10

- Connect the other end of hose (G) to the hand shower (E), making sure the pre-installed components (check valve (F) and gasket (B)) are in place.

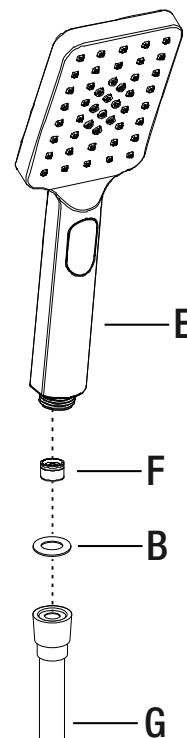

Fig.12

- Connect the hex connector of hose (G) to the bottom of slider arm (I), making sure the pre-installed strainer gasket (Q) is in place.

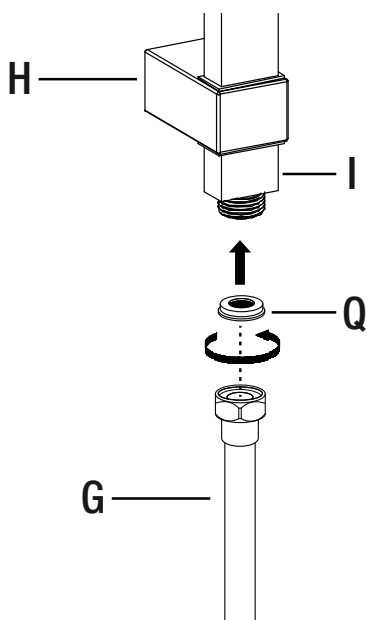

Fig.11

Operation

To use the rainshower system first turn on and adjust the temperature of your existing shower valve then use the diverter (K) to direct the water as described below.

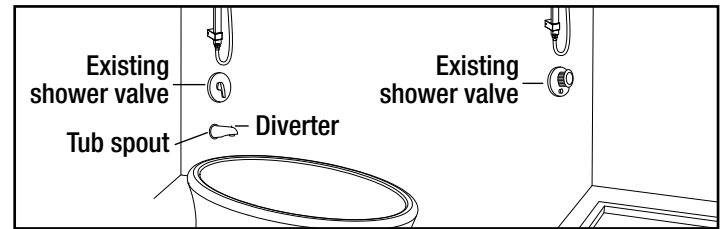
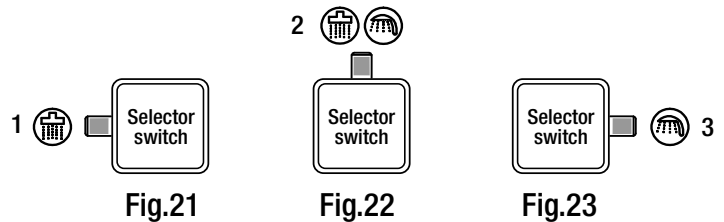

Fig.20

Use the diverter (K) to direct the water flow to the rainshower (fig 21), or handshower (fig. 23), or both (fig. 22)



Troubleshooting

- Make sure that the rubber washers are properly installed to prevent leaks.
- If you find that water pressure or volume is low, clean the mesh gasket and make sure nothing is blocking the flow restrictors.
- If there is no water flow, inspect the check valve to make sure it has been installed correctly. Inspect flow restrictors for debris.

Maintenance

- After use, rinse the shower column with water using the handheld shower to remove any soap deposits. Should water spots occur, clean with a mild solution of vinegar and water followed by a thorough rinse.
- Use liquid soap, a general household cleaner, or a weak solution of vinegar and water for regular cleaning.
- Never use abrasive cleaners as they will scratch the finish.

Replacement Parts

If you are missing parts or if you require replacement parts, please contact our customer service team at cs@conglomkb.com or +61 1800 CONGLOM (Service available Monday - Friday from 6:30 am - 3 pm AEDT). Identify the required part(s) and have the part number(s) ready.

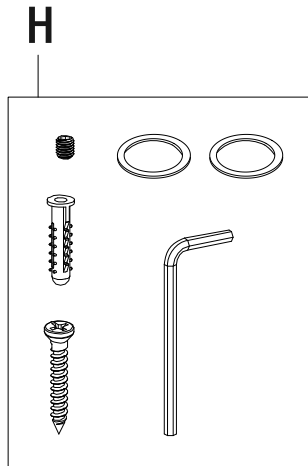
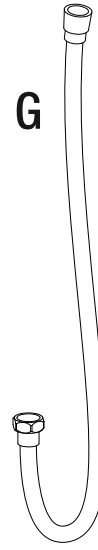
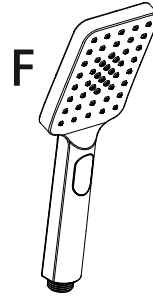
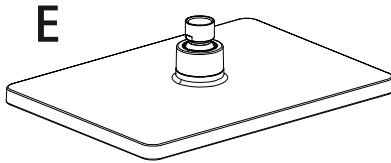
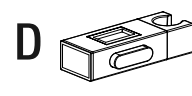
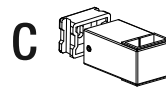
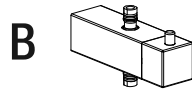

Part	Description	Code	Qty
A	Flange cover	QHB163	1
B	Diverter	QHB164	1
C	Bottom bracket	QHB165	1
D	Hand shower holder	QHB166	1
E	Shower head	QHB168	1
F	Hand shower	QHB169	1
G	Hose	QHB170	1
H	Accessory bag	QHB167	1

Imported by:

Conglom

Conglom International
275 Kurrajong Rd
Prestons
NSW 2170
Australia

+61 1800 CONGLOM | cs@conglomkb.com
(service available Monday - Friday from 6:30 am - 3 pm AEDT)
www.conglomkb.com

Made in China